

MAXIMUM LEAF WEIGHT	MAXIMUM LEAF LENGTH	USE
UP TO 1000 kg	UP TO 20 m	INTENSIVE USE



Solution for sliding gates at private homes and apartment blocks

- Operator with encoder also in the rapid version.
- Ready for operation in case of power outage.
- Ready for installation of magnetic limit switches and heater.
- Control board with terminal blocks, display and storage for up to 250 users.
- Self-diagnosing safety devices.
- Paired connection via RSE accessory.
- Developed with CONNECT technology for remote digital control via gateway or locally via CAME KEY.

Dimensions (mm)

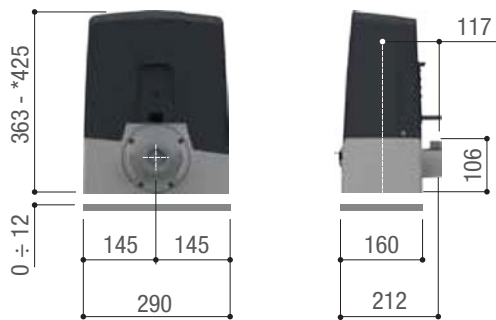

* 801MS-0160 - 801MS-0190 - 801MS-0250

Battery type

MODEL	BATTERY TYPE (not supplied)	MODEL	BATTERY TYPE (not supplied)
801MS-0150	2 x 12 V - 1.3 Ah	801MS-0230	2 x 12 V - 1.3 Ah
801MS-0160	2 x 12 V - 5 Ah	801MS-0250	2 x 12 V - 5 Ah
801MS-0180	2 x 12 V - 1.3 Ah	801MS-0570	2 x 12 V - 1.3 Ah
801MS-0190	2 x 12 V - 5 Ah	801MS-0590	2 x 12 V - 1.3 Ah
801MS-0210	2 x 12 V - 1.3 Ah	801MS-0580	2 x 12 V - 1.3 Ah

Operational limits

MODELS	801MS-0150	801MS-0180	801MS-0210	801MS-0230	801MS-0160	801MS-0190	801MS-0250	801MS-0570	801MS-0580	801MS-0590
Max. length of leaf (m)	14	18	20	20	14	18	20	14	18	20
Max. weight of leaf (kg)	400	600	800	1000	400	600	1000	400	600	1000
Pinion module	4	4	4	4	4	4	4	4	4	4

Technical characteristics

MODELS	801MS-0150	801MS-0180	801MS-0210	801MS-0230	801MS-0160
Protection rating (IP)	54	54	54	54	54
Power supply (V - 50/60 Hz)	230 AC	230 AC	230 AC	230 AC	230 AC
Power supply to motor (V)	24 DC	24 DC	24 DC	24 DC	24 DC
Power (W)	170	270	400	400	240
Maneuvering speed (m/min)	12	12	11	11	22
Duty/cycle (%)	HEAVY-DUTY SERVICE	HEAVY-DUTY SERVICE	HEAVY-DUTY SERVICE	HEAVY-DUTY SERVICE	HEAVY-DUTY SERVICE
Cycles/Hour	-	-	-	-	-
Thrust (N)	350	600	800	1000	250
Operating temperature (°C)	-20 ÷ +55	-20 ÷ +55	-20 ÷ +55	-20 ÷ +55	-20 ÷ +55